

## Digital Undercounter ecostore HP Concept Freezer Counter, 2 Doors with cooling unit right (R290)

ITEM # \_\_\_\_\_

MODEL # \_\_\_\_\_

NAME # \_\_\_\_\_

SIS # \_\_\_\_\_

AIA # \_\_\_\_\_

**710359 (EK2ADAA)**

 2-door Freezer  
 Counter, -22-15°C, AISI 304  
 (R290), with right cooling  
 unit

### Short Form Specification

Item No. \_\_\_\_\_

AISI 304 stainless steel panels, AISI 430 bottom panel, galvanized back panel. Worktop thickness 50mm. N. 2 full doors. Built-in refrigeration unit. Automatic defrost. Operating temperature: -15-22°C. R290 gas in refrigeration circuit. Supplied with 1 grid for each door compartment

### Main Features

- Adjustable temperature range from -15°C to -22°C.
- Certified safety CE requirements.
- Combination of doors and drawers to suit any configuration need, with the possibility to change the configuration on site.
- 0mm clearance installation space: tower configuration cooling unit guarantee performance with frontal ventilation only; this unique solution allows installation against the wall or side by side with other appliances, even on the cooling unit side to maximize the use of kitchen space.
- Frontal and easy access to all components in the cooling unit.
- Anti-tilt runners accept GN 1/1 containers.
- Self closing stainless steel doors (< 90°).
- Prearranged to fit RS485 port to facilitate connection to a remote computer and integrated HACCP systems.
- Equipped with forced air circulation system for rapid cooling and temperature distribution within the cell.
- Digital white-digit display with internal temperature display and setting, manual activation of defrost cycle and turbo frost cycle (to rapidly cool warm loads).
- Tropicalized unit.

APPROVAL: \_\_\_\_\_

### Construction

- Interior base with rounded corners, pressed from a single sheet.
- 2 compartments with 2 doors.
- If needed, working top can be removed for easier handling during installation (in case of narrow doors).
- Ease of cleaning and high hygiene standards thanks to the rounded internal corners, the easily removable runners, grids and air conveyors.
- Internal structure with 15 charging positions (3 cm pitch) available to host GN 1/1 grids, ensuring higher net capacity and a greater storage space.
- Anti-drip profile on stainless steel worktop edge.
- Internal and external doors, front and side panels and removable worktop in AISI 304 Stainless steel.
- Built-in refrigeration unit.
- Developed and produced in ISO 9001 and ISO 14001 certified factory.
- Fault code display.
- Mounted on Stainless steel legs to give 150 mm clearance for ease of cleaning the floor.
- Worktop in AISI 304 Stainless steel with a 50 mm profile.
- Excellent space optimisation thanks to the compact dimensions.
- Extractable cooling unit to facilitate maintenance.
- External bottom panel in stainless steel.
- External back panel in galvanized steel.

### Sustainability



- Fitted with 90 mm thickness of cyclopentane insulation for best insulating performance (thermal conductivity: 0,020 W/m\*K) and lowest environmental impact (GWP=3).
- Removable triple-chamber balloon magnetic gasket to improve insulation and reduce energy consumption and ease of cleaning.
- CFC and HCFC free, highly ecological refrigerant type: R290 (ecological gas in foam: cyclopentane). Hydrocarbon refrigerant gas R290 for the lowest environmental impact (GWP=3), to reduce green house and ozone depletion effects.
- Hot gas automatic evaporation of defrost water.

### Included Accessories

- 2 of Kit 1/1 grey rilsan grid and 2 side runners for refrigerated counters PNC 881109

### Optional Accessories

- 2x½ drawer kit for refrigerated counters PNC 881058
- 3x1/3 drawer kit for refrigerated counters PNC 881059
- 1/1GN grey rilsan grid for refrigerated counters PNC 881107
- 2 side runners for 1/1 GN ecostore refrigerated counters PNC 881108
- Kit 1/1 grey rilsan grid and 2 side runners for refrigerated counters PNC 881109
- 1/1 GN plastic container, H=65 mm PNC 881110
- 1/1 GN plastic container, H=100 mm PNC 881111
- 1/1 GN plastic container, H=150 mm PNC 881112
- Kit 4 wheels, H=100 mm (2 with brakes) for refrigerated counters PNC 881191
- Kit 4 wheels, H=150 mm (2 with brakes) for 2&3 compartment refrigerated counters PNC 881193
- Lock for refrigerator/freezer counters with 2 compartments - h700mm (can be used in kit for Marine conversion) PNC 881242
- IoT module for refrigerated cabinets and counters PNC 881298

Side

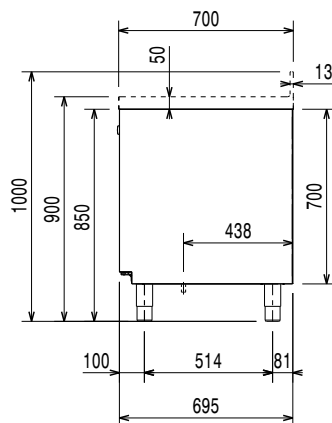

Front

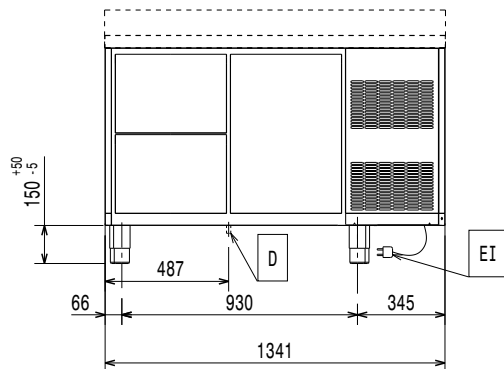

EI = Electrical inlet (power)

Top

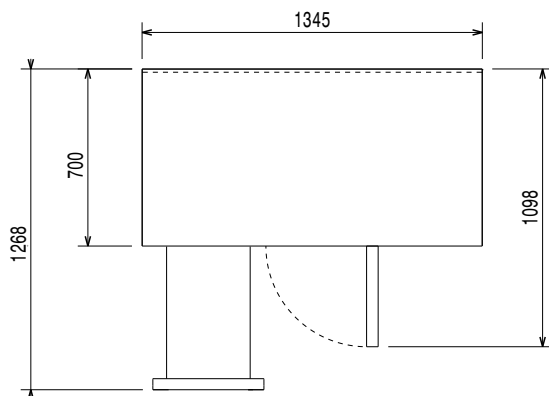

## Electric

Supply voltage:	220-240 V/1 ph/50 Hz
Electrical power, max:	0.49 kW
Defrost Power:	0.57 kW
Plug type:	CE-SCHUKO

## Key Information:

Net Volume:	177.4 lt
Door hinges:	
External dimensions, Width:	1345 mm
External dimensions, Depth:	700 mm
External dimensions, Height:	900 mm
Internal Dimensions, Width:	798 mm
Internal Dimensions, Depth:	560 mm
Internal Dimensions, Height:	550 mm
Net weight:	115 kg
Shipping volume:	1.13 m <sup>3</sup>
Depth with doors open:	1110 mm
Height adjustment:	0/0 mm
Gross capacity:	290 lt

## Refrigeration Data

Control type:	Digital
Refrigeration power at evaporation temperature:	-30 °C
Min/Max internal humidity:	
Operating temperature min.:	-15 °C
Operating temperature max.:	-22 °C
Compressor power:	
Operating mode:	Ventilated
Insulation:	90 mm (Cyclopentane)

## ISO Certificates

ISO Standards:	ISO 9001; ISO 14001; ISO 45001; ISO 50001
----------------	---

## Sustainability

Current consumption:	3.3 Amps
Refrigerant type:	R290
GWP Index:	3
Refrigeration power:	569 W
Refrigerant weight (unit 1):	145 g
Energy Class (EU Reg. 2015/1094):	C
Yearly and daily energy consumption (EU Reg. 2015/1094):	1564kWh/year - 4.28kWh/24h
Climate class (EU Reg. 2015/1094):	Heavy Duty (5)
Energy Efficiency Index-EEL (EU Reg. 2015/1094):	45,78

**EU energy labelling from 1st July 2016**

The European energy labelling scheme for professional refrigerators and freezers is based on requirements setting Minimum Energy Performance standards for commercial refrigeration cabinets sold within the EU. These requirements are designed to drive energy efficiency and environmentally friendly approach for professionals. The European energy labelling scheme will apply to all manufacturers and importers who sell and market products within the EU and it is mandatory across Europe. Important: all products which consume energy above the minimum level will not be able to be sold within the EU from 1 July 2016.

SI 2020 No. 1528.

Important: all products which consume energy above the minimum level will not be able to be sold within the EU from 1 July 2016.

